

PB 100

Small, compact, versatile.



PRODUCT HIGHLIGHTS

- ⊕ Clean 6-cylinder engine with 256 metric HP (188 kW) and powerful torque (Tier 4f and EU Stage V)
- ⊕ Intuitive joystick for proportional control of 4 blade functions at the same time
- ⊕ iTerminal with touch display and color-coded function feedback of the active vehicle parts for easy operation
- ⊕ Storage of 4 driving settings
- ⊕ Precise, proportional auxiliary hydraulics
- ⊕ AutoTracer: Assistance system for ideal grooming results
- ⊕ Independent tiller depth adjustment: Position of the foldable side finishers and alignment of the tracking plates unit are not affected
- ⊕ Practical holders for backpack, tool and smartphone
- ⊕ The best panoramic view thanks to halogen/LED lighting and ramp mirrors

CAB

Comfort heating system	With automatic function and stepless temperature adjustment
Driver's seat	Air-suspended, adjustment positions, seat heating unit
Control elements	Joystick for 4 simultaneous movements, iTerminal, armrest, steering wheel control
Windows	Windshield and rear window heated, side windows sliding and heated
Outside mirrors	Heated and electrically adjustable, wide-angle, approach mirror
Wipers	Coolant-heated, heating turned on and off electrically

LIGHTING

Front	4 halogen headlights 2 LED worklights on grab bar
Rear	2 LED worklights

AUXILIARY EQUIPMENT

Nordic all way blades 2.8 m/3.2 m	Optimized Nordic guide rail for blade usage
SmartCut snow tillers 2.5 m/2.8 m/3.1 m	With SmartCut tiller teeth and optimized finishers
QCS	Swap system with parallel kinematics

OPTIONS

Alpine all way blades 2.8 m/3.2 m	Luxury seat
Brush guard	NoDeck version
Solid rubber wheels	ProMount
Front high-pressure connection (technology package)	LED lighting package, dimmable with 3rd headlight center rear
implement carrier with vibration compensation during lifting/lowering	SnowSat fleet management and snow depth measurement with LiDAR
Implement carrier with side damping when swinging	Radio with Apple CarPlay and Android Auto
Rear camera	Auxiliary heating
Hydraulic oil preheating	Drive control stick
Reinforced tensioning and 4th idler axle	Tracking plates with/without track tiller
Cab for 5, 8 or 10 persons	1 halogen or 1 LED searchlight
Air conditioning	Central locking

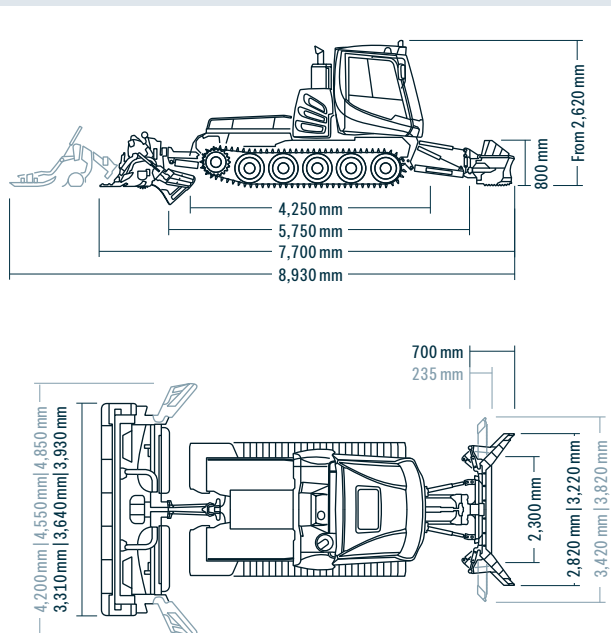

DIMENSIONS

	Without tracks and fenders	2,300 mm
	Over tracks 810 mm (combi)	2,480 mm
Width	Over tracks 825 mm (X-Track/steel)	2,510 mm
	Over tracks 970 mm (combi/X-Track/steel)	2,800 mm
	Over tracks 1,130 mm (combi/X-Track)	3,120 mm
Height	Total for Solo (depending on the additional options)	2,620 mm - 2,740 mm
	With driver's cab tilted	3,350 mm
Loading platform	Length	1,620 mm
	Width	1,920 mm
Ground clearance		320 mm

WEIGHTS (FROM)

	Vehicle without tracks / quick-change system	from 4410 kg
	Combi tracks 810 mm	760 kg
	Combi tracks 970 mm	790 kg
	Combi tracks 1,130 mm	960 kg
Empty weight	X-track chains 825 mm	990 kg
	X-track chains 970 mm	1,000 kg
	X-track chains 1,130 mm	1,250 kg
	Steel tracks 825 mm	1,350 kg
	Steel tracks 970 mm	1,460 kg
	Operating weight**	Vehicle with combi tracks/front blade/tiller
Permitted gross weight (in accordance with ROPS)		8,500 kg
Payload, load platform		1,500 kg

** Minimum operating weight (according to standard)

ENGINE

Type	Cummins B 6.7
Number of cylinders	6
Displacement	6,700 cm ³
Power in accordance with ECE	188 kW / 256 hp (metric)
Exhaust gas standard	Tier 4f/EU Stage V/China IV
Max. torque	1,152 Nm @ 1,500 rpm
Tank capacity	210 l
DEF (AdBlue®) tank capacity	16 l
Fuel consumption	from 8.5 l/h

DRIVING CHARACTERISTICS

Speed	Stepless from 0 - 25 km/h
Turning radius	On the spot

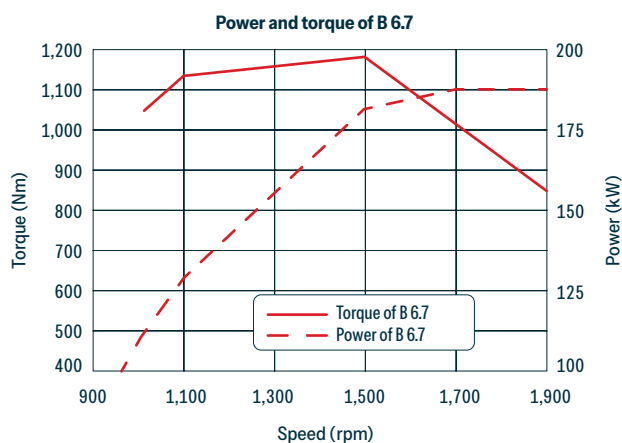

Contact

Fast. Direct. In person.
Find your contact person here.

www.pistenbully.com

 **KÄSSBOHRER ALL TERRAIN VEHICLES INC.**